

BWD-K

Pompe a pistoni ad alta pressione

High Pressure piston pump • Bombas de pistones de alta presión



BWD-K 3400 RPM



(G Version) **BWD-K**

- **ALBERO FEMMINA Ø3/4"**
per motore a scoppio flangia SAE J 609 A. Flangia inclusa.
- **HOLLOW SHAFT 3/4"**
for petrol engine, flange SAE J 609A. Flange included.
- **ARBOL HEMBRA Ø3/4"**
para motor de explosión Brida SAE J 609. Brida incluida.



(E Version) **BWD-K**

- **ALBERO FEMMINA Ø5/8"**
per motore elettrico NEMA 56 C. Flangia inclusa.
- **HOLLOW SHAFT 5/8"**
for NEMA 56 C electric motor. Flange included.
- **ARBOL HEMBRA Ø5/8"**
para motor eléctrico NEMA 56C. Brida incluida.

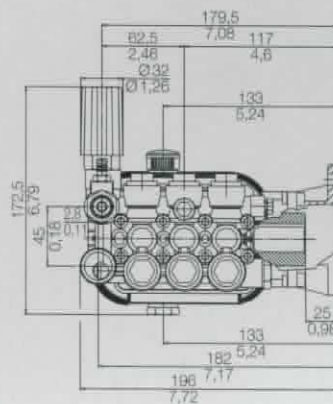
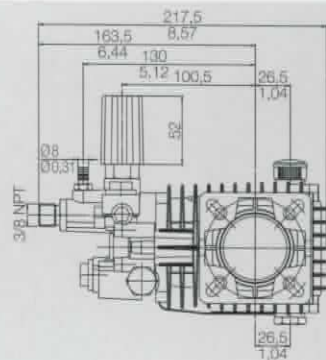
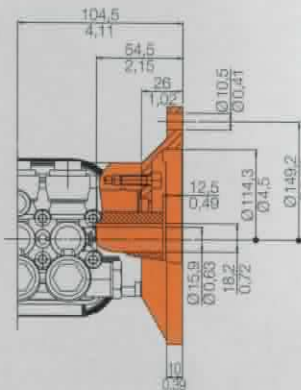
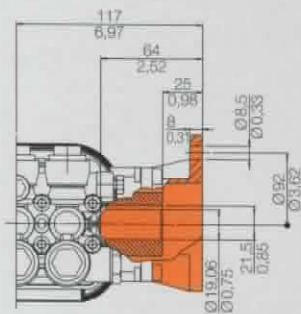

giri/min R.P.M. rev/min	modello model modelo	versione version versione	portata flow rate caudal		pressione pressure presión		potenza assorbita absorbed power potencia absorbida		peso weight peso	
			l/min	US gpm	bar	psi	kW	HP	kg	lb
3400	BWD-K 2020	E	7,1	1,9	138	2000	2,0	2,7	6,0	13,3
	BWD-K 2527	G	9,8	2,6	186	2700	3,7	5,0	6,0	13,3
	BWD-K 3020	E	10,0	2,7	138	2000	2,7	3,7	6,0	13,3
	BWD-K 3020	G	11,3	3,0	138	2000	3,2	4,3	6,0	13,3
	BWD-K 3027	G	11,3	3,0	186	2700	4,3	5,8	6,0	13,3

■ Tutti i modelli sono forniti con testata in ottone e in versione standard con presa di moto lato destro.

■ All models supplied with brass head. Standard versions with p.t.o on right hand side.

■ Todos los modelos están disponibles con cabeza de latón y en las versiones estándar con toma de movimiento sobre el lado derecho.